



Offshore Special Regulations

Extract for Monohull Category 3

JANUARY 2026 – DECEMBER 2027

© ORC Ltd. 2002, amendments 2003-2026 © World Sailing Limited

Sail Canada Version 1 – 6 January 2026



Because this is an extract not all paragraph numbers will be present

Copyright

When reprinting these regulations Member National Authorities and Organising Authorities should:

- When reprinting these regulations Member National Authorities and Organising Authorities should:
- request copyright permission from World Sailing and ORC Ltd (normally given free of charge),
- display a copyright acknowledgement with the reprint (similar to © ORC Ltd. 2002, amendments 2003-2026 © World Sailing Limited),
- make any amendments by deleting contrary provisions,
- indicate that changes have been made, and
- supply a copy of the reprint to each of World Sailing and ORC Ltd.

Official interpretations shall take precedence over these Special Regulations and will be indexed, numbered, dated and displayed on the World Sailing website:

<https://www.sailing.org/inside-world-sailing/rules-regulations/offshore-special-regulations/>

Language & Abbreviations Used

Mo – Monohulls

Mu – Multihulls

** – means the item applies to all types of boat in all Categories except 5 for which see Appendix B or 6 for which see Appendix C.

The use of the masculine gender shall be taken to mean either gender.

Style Conventions Used

RED TYPE indicates a significant change in 2026.

DOUBLE UNDERLINE TYPE indicates a term defined in Offshore Special Regulation 1.03.1.

ITALIC TYPE indicates a term defined in the Racing Rules of Sailing.

Other than in headings or in offshore special regulation 1.02.1, **BOLD BLACK TYPE** indicates a term defined in the Equipment Rules of Sailing.

BOLD BLUE TYPE indicates a Sail Canada prescription.

Administration

The Offshore Special Regulation are administered by the World Sailing Special Regulation Sub-Committee whose terms of reference (available at <https://www.sailing.org/>) are as follows:

INTRODUCTION

3.1 The remit of the Sub-committee is to advise and report to the Oceanic & Offshore Committee on:

- (a) the maintenance, revision and changes to the World Sailing Offshore Special Regulations governing offshore racing, under licence from ORC Limited, and any interpretations (changes to be biennial with revised editions published in January of each even year, except that matters of an urgent nature affecting safety may be dealt with by changes to the Regulations on a shorter time scale); and
- (b) developments in offshore racing relative to the standards of safety and seaworthiness.

Any queries please email: technical@sailing.org

For any queries regarding Sail Canada prescriptions please email: offshore@sailing.ca

Contents

SECTION 1 – FUNDAMENTAL AND DEFINITIONS.....	3
SECTION 2 – APPLICATION & GENERAL REQUIREMENTS	6
SECTION 3 – STRUCTURAL FEATURES, STABILITY, FIXED EQUIPMENT.....	7
SECTION 4 – PORTABLE EQUIPMENT	15
SECTION 5 – PERSONAL EQUIPMENT	20
SECTION 6 – TRAINING	22
APPENDIX F – Inspection Card	23

Appendices

- APPENDIX A – Moveable and Variable Ballast
- APPENDIX B – For Inshore Racing
- APPENDIX C – For Inshore Dinghy Racing
- APPENDIX D – A Guide to ISO and other Standards
- APPENDIX E – World Sailing Code for the Organisation of Oceanic Races
- APPENDIX F – *See the link in Contents (above)*
- APPENDIX G – Model Training Course
- APPENDIX H – Model First Aid Training Course
- APPENDIX J – Hypothermia
- APPENDIX K – Drogues and Sea Anchors
- APPENDIX L – Model Keel and Rudder Inspection Procedure
- APPENDIX M – Optional Wording for Organising Authorities’ NoRs or SIs

The appendices, other than appendix F, are available at <https://www.sailing.org>

SECTION 1 – FUNDAMENTAL AND DEFINITIONS

Categories	1.01	Purpose and Use																
**	1.01.1	The purpose of the Offshore Special Regulations (<u>OSR</u>) is to establish uniform minimum equipment, accommodation and training standards for monohull and multihull (excluding proa [asymmetrical catamaran]) boats racing offshore.																
**	1.01.2	The <u>OSR</u> do not replace, but supplement, the requirements of governmental authority, Classification Society certification, the Racing Rules of Sailing (<u>RRS</u>), Equipment Rules of Sailing (ERS), class rules and rating systems.																
**	1.01.3	Use of the <u>OSR</u> does not guarantee total safety of the boat and her crew. Particular attention is drawn to the description of <u>OSR</u> for inshore racing which includes that adequate shelter and or effective rescue is available all along the course. This is not included in more onerous <u>OSR</u> categories.																
	1.02	Responsibility of Person in Charge																
**	1.02.1	Under <u>RRS</u> 3 the responsibility for a boat’s decision to participate in a race or continue racing is hers alone. The safety of a boat and her crew is the sole and inescapable responsibility of the <i>person in charge</i> who shall do his best to ensure that the boat is fully found, thoroughly seaworthy and manned by an experienced and appropriately trained crew who are physically fit to face all weather. The <i>person in charge</i> shall also assign a person to take over his responsibilities in the event of his incapacitation.																
**	1.02.2	Neither the establishment of the <u>OSR</u> , nor their use by <i>organising authorities</i> , nor the inspection of a boat under the <u>OSR</u> in any way limits or reduces the complete and unlimited responsibility of the <i>person in charge</i> .																
**	1.02.3	By participating in a race conducted under the <u>OSR</u> , the <i>person in charge</i> , each competitor and boat owner agrees to reasonably cooperate with the <i>organising authority</i> and World Sailing in the development of an independent incident report as specified in <u>OSR</u> 2.02.																
	1.03	Definitions, Abbreviations, Word Usage																
**	1.03.1	Table 1 – Definitions of Terms used in this document																
		<table border="1"> <thead> <tr> <th>Abbreviation</th> <th>Description</th> </tr> </thead> <tbody> <tr> <td>#</td> <td>Pound force (lbf)</td> </tr> <tr> <td>ABS</td> <td>American Bureau of Shipping</td> </tr> <tr> <td>AIS</td> <td>Automatic Identification Systems</td> </tr> <tr> <td>Coaming</td> <td>The part of the cockpit, including the transverse after limit, over which water would run when the boat is floating level and the cockpit is filled to overflowing</td> </tr> <tr> <td>COLREGS</td> <td>International Regulations for Preventing Collisions at Sea</td> </tr> <tr> <td>Contained Cockpit</td> <td>A cockpit where the combined area open aft to the sea is less than 50% maximum cockpit depth x maximum cockpit width</td> </tr> <tr> <td>Crewmember</td> <td>Every person on board</td> </tr> </tbody> </table>	Abbreviation	Description	#	Pound force (lbf)	ABS	American Bureau of Shipping	AIS	Automatic Identification Systems	Coaming	The part of the cockpit, including the transverse after limit, over which water would run when the boat is floating level and the cockpit is filled to overflowing	COLREGS	International Regulations for Preventing Collisions at Sea	Contained Cockpit	A cockpit where the combined area open aft to the sea is less than 50% maximum cockpit depth x maximum cockpit width	Crewmember	Every person on board
Abbreviation	Description																	
#	Pound force (lbf)																	
ABS	American Bureau of Shipping																	
AIS	Automatic Identification Systems																	
Coaming	The part of the cockpit, including the transverse after limit, over which water would run when the boat is floating level and the cockpit is filled to overflowing																	
COLREGS	International Regulations for Preventing Collisions at Sea																	
Contained Cockpit	A cockpit where the combined area open aft to the sea is less than 50% maximum cockpit depth x maximum cockpit width																	
Crewmember	Every person on board																	

SECTION 1 – FUNDAMENTAL AND DEFINITIONS

Categories		
	DSC	Digital Selective Calling
	EN	European Norm
	EPIRB	Emergency Position-Indicating Radio Beacon
	ERS	World Sailing - Equipment Rules of Sailing
	First Launch	Month & year of the first launching when the individual boat, was completed and equipped for sailing
	GMDSS	Global Maritime Distress & Safety System
	GNSS	Global Navigation Satellite System
	Hatch	The term hatch includes the entire hatch assembly including the lid or cover as part of that assembly
	HMPE	High Modulus Polyethylene (Dyneema [®] /Spectra [®] or equivalent)
	IBRD	International Beacon Registration Database
	IMO	International Maritime Organization
	ISAF	International Sailing Federation – (now World Sailing)
	ISO	International Standard Organization or International Organization for Standardization
	Jackstay	A <u>securely fastened</u> webbing or rope which permits a <u>crewmember</u> to move from one part of the boat to another without having to unclip a deck safety harness <u>tether</u>
	LH	Hull Length as defined by the ERS
	Lifeline	Rope or wire line rigged as guardrail/guardline around the deck
	LSA	<u>IMO</u> International Life-Saving Appliance Code
	LWL	(Length of) loaded waterline
	Moveable Ballast	Material carried for the sole purpose of increasing weight and/or influencing stability and/or trim and which may be moved transversely but not varied in weight while a boat is racing
	ORC	Offshore Racing Congress (formerly Offshore Racing Council)
	OSR	Offshore Special Regulation(s)
	Permanently Installed	The item is effectively built-in by e.g. bolting, welding, glassing etc. and may not be removed for or during racing
	PLB	Personal Locator Beacon
	Rode	Rope, chain, or a combination of both, which is used to connect an anchor to the boat
	RRS	World Sailing – Racing Rules of Sailing

SECTION 1 – FUNDAMENTAL AND DEFINITIONS

Categories

Securely Fastened	Held strongly in place by a method (e.g. rope lashings, wing nuts) which will safely retain the fastened object in severe conditions including a 180° capsized and allows for the item to be removed and replaced during racing
SOLAS	Safety of Life at Sea Convention
SSS	The Safety and Stability Screening numeral
STCW	Standards of Training, Certification and Watchkeeping for Seafarers
STIX	ISO 12217-2 Stability Index
Tether	A line or webbing used to connect a deck safety harness to a strong point or <u>jackstay</u>
Variable Ballast	Water carried for the sole purpose of influencing stability and/or trim and which may be varied in weight and/or moved while a boat is racing.
World Sailing	formerly the International Sailing Federation or <u>ISAF</u>

** 1.03.2 The words “shall” and “must” are mandatory, and “should” and “may” are permissive.

SECTION 2 – APPLICATION & GENERAL REQUIREMENTS

Categories	2.01	Categories of Events
**		<i>Organising authorities</i> shall select from one of the following categories and may modify the <u>OSR</u> to suit local conditions.
MoMu3	2.01.4	Category 3
		Races across open water, most of which is relatively protected or close to shorelines.
**	2.02	Incident Reporting
		The <i>organising authority</i> of a race will establish whether any incidents occurred, which if reported would likely be relevant to evolving the Offshore Special Regulations, the plan review process, or in increasing safety. The <i>organising authority</i> will follow any guidelines issued by World Sailing concerning incident reporting.
**	2.03	Inspection
		A boat may be inspected at any time. If she fails to comply with the <u>OSR</u> her entry may be rejected, or she will be subject to protest.
**	2.04	General Requirements
**	2.04.1	All equipment required by <u>OSR</u> shall:
**		a) function properly,
**		b) be regularly checked, cleaned and serviced,
**		c) if it has an expiry date, it will not have exceeded its expiry date whilst racing,
**		d) when not in use to be stowed in conditions which minimise deterioration,
**		e) be readily accessible, and
**		f) be of a type, size and capacity suitable and adequate for the intended use and size of the boat.
**	2.04.2	Heavy items shall be <u>permanently installed</u> or <u>securely fastened</u> .

SECTION 3 – STRUCTURAL FEATURES, STABILITY, FIXED EQUIPMENT

Categories	A boat shall be/have:																
	3.01	Strength of Build and Rig															
**	3.01.1	Properly rigged, fully seaworthy and shall meet the <u>OSR</u> .															
**	3.01.2	Equipped with shrouds and at least one forestay that shall remain connected to the mast and the boat while racing (not applicable to boats with free-standing masts).															
**	3.01.3	The forestay referenced above shall be sized and connected in a way that ensures it is capable of withstanding the full sailing loads independent of any headsail luff load capacity.															
	3.02	Watertight and Structural Integrity of a Boat															
**	3.02.1	Essentially watertight and all openings shall be capable of being immediately secured. Centreboard or daggerboard trunks and the like shall not open into the interior of a hull except via a watertight maintenance <u>hatch</u> with the opening entirely above the waterline .															
Mo3	3.02.4	At a haul-out within 2 years prior to the event, the owner or his/her representative shall inspect the integrity of the keel and rudder following the recommendations in Appendix L.															
Mo0,1,2,3	3.02.5	Inspection after Grounding – an appropriately qualified person shall conduct an internal and external inspection after each unintentional grounding.															
	3.04	Stability – Monohulls															
Mo3	3.04.1	c) Compliant with <u>ISO</u> 12217-2 ^a design category B, or higher or the requirements of <u>OSR</u> 3.04.2, <u>OSR</u> 3.04.3 or <u>OSR</u> 3.04.4.															
Mo0,1,2,3		^a This can be demonstrated either by EC Recreational Craft Directive certification having obtained the CE mark or by the designer’s declaration. The latest effective version of <u>ISO</u> 12217-2 should be used unless the boat was already designed to a previous version.															
Mo0,1,2,3	3.04.2	Table 2 – STIX, AVS and m*AGZ															
		<table border="1"> <thead> <tr> <th>Race Category</th> <th>0,1,2</th> <th>3</th> </tr> </thead> <tbody> <tr> <td>minimum <u>ISO</u> 12217-2 Stability Index (STIX)</td> <td>32</td> <td>23</td> </tr> <tr> <td>minimum <u>ISO</u> 12217-2 Angle of Vanishing Stability (AVS)</td> <td>130- 0.002*m^c</td> <td>130- 0.005*m^c</td> </tr> <tr> <td>but AVS always >=</td> <td>100°</td> <td>95°</td> </tr> <tr> <td>a minimum righting energy m*AGZ (where AGZ is the positive area under the righting lever curve in the minimum operating condition, expressed in kg metre degrees from upright to AVS)</td> <td>172 000</td> <td>57 000</td> </tr> </tbody> </table>	Race Category	0,1,2	3	minimum <u>ISO</u> 12217-2 Stability Index (STIX)	32	23	minimum <u>ISO</u> 12217-2 Angle of Vanishing Stability (AVS)	130- 0.002*m ^c	130- 0.005*m ^c	but AVS always >=	100°	95°	a minimum righting energy m*AGZ (where AGZ is the positive area under the righting lever curve in the minimum operating condition, expressed in kg metre degrees from upright to AVS)	172 000	57 000
Race Category	0,1,2	3															
minimum <u>ISO</u> 12217-2 Stability Index (STIX)	32	23															
minimum <u>ISO</u> 12217-2 Angle of Vanishing Stability (AVS)	130- 0.002*m ^c	130- 0.005*m ^c															
but AVS always >=	100°	95°															
a minimum righting energy m*AGZ (where AGZ is the positive area under the righting lever curve in the minimum operating condition, expressed in kg metre degrees from upright to AVS)	172 000	57 000															
Mo0,1,2,3		^c where “m” is the mass of the boat in the minimum operating condition as defined in <u>ISO</u> 12217-2.															

SECTION 3 – STRUCTURAL FEATURES, STABILITY, FIXED EQUIPMENT

Categories	A boat shall be/have:																			
Mo0,1,2,3	3.04.3	Table 3 – ORC Stability Index	<table border="1"> <thead> <tr> <th>Race Category</th> <th>0</th> <th>1</th> <th>2</th> <th>3</th> </tr> </thead> <tbody> <tr> <td>minimum Stability Index in <u>ORC</u> Rating System, or</td> <td>120</td> <td>115</td> <td>110</td> <td>103</td> </tr> </tbody> </table>			Race Category	0	1	2	3	minimum Stability Index in <u>ORC</u> Rating System, or	120	115	110	103					
Race Category	0	1	2	3																
minimum Stability Index in <u>ORC</u> Rating System, or	120	115	110	103																
	3.04.4		<table border="1"> <thead> <tr> <th>Race Category</th> <th>0,1,2</th> <th>3</th> </tr> </thead> <tbody> <tr> <td>For tables 2 and 3, Sail Canada Prescribes that if the minimum righting energy (above) is not available, the boat shall have a minimum sailing weight "m" of:</td> <td>3 000 kg</td> <td>1 500 kg</td> </tr> </tbody> </table>			Race Category	0,1,2	3	For tables 2 and 3, Sail Canada Prescribes that if the minimum righting energy (above) is not available, the boat shall have a minimum sailing weight "m" of:	3 000 kg	1 500 kg									
Race Category	0,1,2	3																		
For tables 2 and 3, Sail Canada Prescribes that if the minimum righting energy (above) is not available, the boat shall have a minimum sailing weight "m" of:	3 000 kg	1 500 kg																		
Mo0,1,2,3		Table 4 – IRC Safety and Stability Screening numeral (SSS)	<table border="1"> <thead> <tr> <th>Race Category</th> <th>0</th> <th>1</th> <th>2</th> <th>3</th> </tr> </thead> <tbody> <tr> <td>SSS may only be used if the series date is before</td> <td></td> <td></td> <td>1995</td> <td>2000</td> </tr> <tr> <td>minimum IRC Safety and Stability Screening numeral (SSS) Base value</td> <td></td> <td></td> <td>28</td> <td>15</td> </tr> </tbody> </table>			Race Category	0	1	2	3	SSS may only be used if the series date is before			1995	2000	minimum IRC Safety and Stability Screening numeral (SSS) Base value			28	15
Race Category	0	1	2	3																
SSS may only be used if the series date is before			1995	2000																
minimum IRC Safety and Stability Screening numeral (SSS) Base value			28	15																
	3.06	Exits – Monohulls																		
Mo0,1,2,3,4	3.06.1	If the series date is after 1994 and L_H is 8.5 m (28') and greater, a boat shall have at least two exits. One exit shall be located forward of the foremost mast except where structural features prevent its installation.																		
Mo0,1,2,3,4	3.06.2	If <u>first launched</u> after 2013, the minimum clear <u>hatch</u> openings shall be:																		
Mo0,1,2,3,4		a) a circular <u>hatch</u> with diameter 450 mm (18"), or																		
Mo0,1,2,3,4		b) any other shape with minimum dimension of 380 mm (15") and minimum area of 0.18 m ² (1.9 ft ²) (see figure 1).																		
Mo0,1,2,3,4																				
		Figure 1 – Measurements of Minimum Clear Opening																		
	3.08	Hatches & Companionways																		
**	3.08.1	<u>Hatch</u> covers forward of the maximum beam station shall not open toward the interior of the boat, except <u>hatches</u> in the side of a coachroof or ports having an area of less than 0.071 m ² (110 in ²).																		
**	3.08.2	A <u>hatch</u> , including a <u>hatch</u> over a locker shall be:																		
**		a) permanently attached and capable of being firmly shut immediately and remaining firmly shut in a 180° capsize,																		
Mo0,1,2,3,4		b) above the water when the boat is heeled 90°.																		

SECTION 3 – STRUCTURAL FEATURES, STABILITY, FIXED EQUIPMENT

Categories	
Mo0,1,2,3,4	A boat shall be/have: A boat may have a maximum of two <u>hatches</u> on each side of centreline that do not conform to the requirement in b), provided that the opening of each is less than 0.071 m ² (110 in ²).
**	3.08.3 <u>Hatches</u> not conforming with <u>OSR</u> 3.08.1 and <u>OSR</u> 3.08.2 shall be clearly labelled and used in accordance with the following instruction “NOT TO BE OPENED AT SEA”.
**	3.08.4 Companionway <u>hatches</u> :
**	a) fitted with a strong securing arrangement which shall be operable from the exterior and interior even when the boat is inverted,
**	b) blocking devices:
**	i) capable of being retained in position with the <u>hatch</u> open or shut,
**	ii) secured to the boat (e.g. by lanyard) for the duration of the race, and
**	iii) permit exit in the event of inversion.
Mo0,1,2,3,4	3.08.5 If a monohull with cockpit(s) that is/are not <u>contained cockpit(s)</u> a boat shall have:
Mo0,1,2,3,4	a) a companionway sill that does not extend below the local sheerline , or
Mo0,1,2,3,4	b) a companionway in full compliance with <u>ISO</u> 11812 category A.
Mo0,1,2,3,4	3.08.6 If a monohull with <u>contained cockpit(s)</u> where the companionway extends below the local sheerline , a boat shall have panels capable of blocking the companionway up to the level of the local sheerline whilst giving access to the interior.
	3.09 Cockpits
	3.09.1 General
**	a) cockpits shall self-drain quickly by gravity at all angles of heel and are permanently incorporated as an integral part of the boat,
**	b) a cockpit sole shall be at least 2% <u>L_{WL}</u> above the waterline (or in IMS boats with <u>first launch</u> before 2003, at least 2% L above the waterline), and
**	c) a bow, lateral, central, or stern well is a cockpit for the purposes of <u>OSR</u> 3.09.
	3.09.2 Cockpit Volume
**	The maximum combined volume below lowest <u>coamings</u> of all <u>contained cockpits</u> shall be:
MoMu2,3,4	b) series date before April 1992: 9% (<u>L_{WL}</u> x maximum beam x freeboard abreast the cockpit),
**	c) series date after March 1992 as above for the appropriate category except that “lowest <u>coamings</u> ” shall not include any aft of the FA station (the transverse station at which the upper corner of the transom meets the sheerline) and no extension of a cockpit aft of the working deck shall be included in calculation of cockpit volume.
	3.09.3 Cockpit Drains
**	Cockpit drain cross section area of unobstructed openings (after allowance for screens if fitted) shall be at least that of:

SECTION 3 – STRUCTURAL FEATURES, STABILITY, FIXED EQUIPMENT

Categories	
**	A boat shall be/have:
**	a) if less than 8.5 m (28') L_H : 2 x 25 mm (1") diameter or equivalent,
**	b) if 8.5 m (28') L_H or greater: 4 x 20 mm (3/4") diameter or equivalent.
3.10	Sea Cocks or Valves
**	<u>Permanently installed</u> sea cocks or valves on all through-hull openings below the waterline except for integral deck scuppers and instrument through-hulls.
3.11	Sheet Winches
**	Sheet winches mounted in such a way that an operator is not required to be substantially below deck.
3.12	Mast Step
**	The heel of a keel stepped mast <u>securely fastened</u> to the mast step or adjoining structure.
3.14	Pulpits, Stanchions, Lifelines
3.14.1	General
**	The perimeter of the deck surrounded by system of <u>lifelines</u> and pulpits as follows:
**	a) continuous <u>lifelines</u> fixed only at (or near) the bow and stern. However, a gate on each side of a boat is permitted. Except at its end fittings and at gates, the movement of a <u>lifeline</u> in a fore-and-aft direction shall not be constrained. Temporary sleeving shall not modify tension in the <u>lifeline</u> ,
**	b) minimum heights of <u>lifelines</u> and pulpit rails above the perimeter of the deck and vertical openings:
**	i upper: 600 mm (24"),
**	ii intermediate: 230 mm (9"),
**	iii vertical opening: no greater than 380 mm (15") except that on a boat with a series date before 1993 where it shall be no greater than 560 mm (22"),
MoMu3,4	iv a boat less than 8.5 m (28') L_H may use a single <u>lifeline</u> system with a height between 450 mm (18") and 560 mm (22").
**	c) <u>lifelines</u> permanently supported at intervals of not more than 2.2 m (7'-2 1/2") and not passing outboard of supporting stanchions,
**	d) pulpit and stanchion bases <u>permanently installed</u> with pulpits and stanchions mechanically retained in their bases,
**	e) the outside of pulpit and stanchion base tubes no further inboard from the perimeter of the deck than 5% of boat beam or 150 mm (6"), whichever is greater, nor further outboard than the perimeter of the deck. If a boat's series date is after 2024 the perimeter of the deck is defined as the hull and deck intersection at an angle of not more than 15° to the horizontal in a transverse plane when the boat is upright,
**	f) stanchions straight and vertical except that:
**	i within the first 50 mm (2") from the deck, stanchions shall not be displaced horizontally from the point at which they emerge from the deck or stanchion base by more than 10 mm (3/8"),

SECTION 3 – STRUCTURAL FEATURES, STABILITY, FIXED EQUIPMENT

Categories

A boat shall be/have:

- ii stanchions may be angled to not more than 10° from vertical at any point above 50 mm (2") from the deck.
- g) a bow pulpit may be open provided the opening between the pulpit and any part of the boat does not exceed 360 mm (14"),

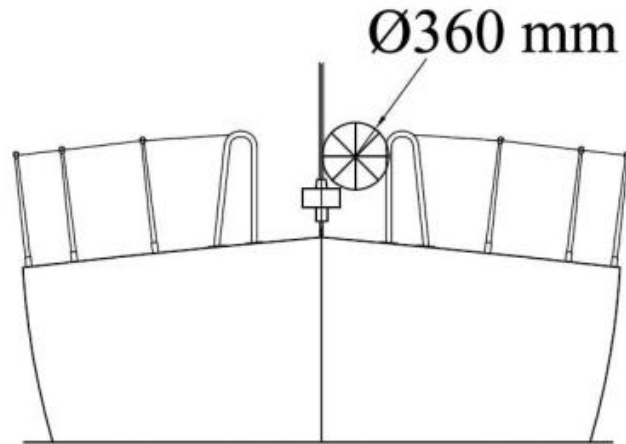

Figure 2 – Diagram Showing Pulpit Opening

- h) lifelines may terminate at or pass through adequately braced stanchions set inside and overlapping the bow pulpit,
- i) when a deflecting force of 4 kg (8.8 #) is applied to a lifeline at the mid-point of the longest span between supports that are aft of the mast, the deflection shall not exceed:
 - i) 50 mm (2") for an upper or single lifeline,
 - ii) 120 mm (4 3/4") for an intermediate lifeline.

3.14.3 Lifeline Specifications

- a) lifelines of stranded stainless steel wire,
- c) The minimum diameter is specified in table 5 below,
- d) Stainless steel lifelines shall be uncoated and used without close-fitting sleeving, however, temporary sleeving may be fitted provided it is regularly removed for inspection,
- e) A lanyard of synthetic rope may be used to secure lifelines provided the gap it closes does not exceed 100 mm (4"). This lanyard shall be replaced annually,
- f) All components of the lifeline enclosure system shall have a breaking strength no less than the lifeline,

Mo0,1,2,3

SECTION 3 – STRUCTURAL FEATURES, STABILITY, FIXED EQUIPMENT

Categories	A boat shall be/have:			
**	Table 5 – Lifeline Diameter Requirements			
	<u>L_H</u>	Wire Min. <u>lifeline</u> diameter	<u>HMPE</u> rope (Single braid) min. <u>lifeline</u> diameter	<u>HMPE</u> Core (Braid on braid) min. <u>lifeline</u> outside diameter
	under 8.5 m (28')	3 mm (1/8")	4 mm (5/32")	6 mm (1/4")
	8.5m – 13 m	4 mm (5/32")	5 mm (3/16")	7 mm (9/32")
	over 13 m (42' 8")	5 mm (3/16")	5 mm (3/16")	7 mm (9/32")
	3.17	Toe Rail or Foot-Stop		
Mo0,1,2,3	3.17.1	<u>Permanently installed</u> toe rail of minimum height 25 mm (1"), located at or no more than 100 mm (4") inboard of the perimeter of the deck from at least forward of the mast.		
Mo0,1,2,3	3.17.2	On a boat with series date before 1984, an additional <u>lifeline</u> of between 25–50 mm (1–2") high is permitted in lieu of a toe rail		
	3.18	Toilet		
MoMu3,4	3.18.2	<u>Permanently installed</u> toilet or fitted bucket.		
	3.19	Bunks		
MoMu1,2,3,4	3.19.1	<u>Permanently installed</u> bunks.		
	3.20	Cooking Facilities		
MoMu0,1,2,3		<u>Permanently installed</u> cooking stove, capable of being operated safely at sea, with fuel shutoff control.		
	3.21	Drinking Water Tanks & Drinking Water		
	3.21.1	Drinking Water Tanks		
MoMu2,3		c) <u>permanently installed</u> delivery pump and water tank(s), or reusable container(s) capable of providing drinking water for the likely duration of the passage.		
	3.21.3	Emergency Drinking Water		
MoMu1,2,3		a) at least 2 L (0.5 US Gal) per person of drinking water for emergency use in a dedicated and sealed container or container(s).		
	3.22	Hand Holds		
**		Adequate hand holds fitted below deck.		
	3.23	Bilge Pumps and Buckets		
**	3.23.1	a) two strong buckets, each with a lanyard and of at least 9 L (2.4 US Gal) capacity,		
Mo3Mu0,1,2		c) one <u>permanently installed</u> manual bilge pump,		
**	3.23.2	All required <u>permanently installed</u> bilge pumps shall be operable with all cockpit seats, <u>hatches</u> and companionways shut and with <u>permanently installed</u> discharge pipe(s) of sufficient capacity.		
**	3.23.3	Bilge pumps shall not be connected to cockpit drains and shall not discharge into a <u>contained cockpit</u> .		

SECTION 3 – STRUCTURAL FEATURES, STABILITY, FIXED EQUIPMENT

Categories		A boat shall be/have:
**	3.23.4	Bilge pumps shall be readily accessible for maintenance and for clearing out debris.
**	3.23.5	All removable bilge pump handles retained by a lanyard.
MoMu0,1,2,3	3.24	Compass
**		Marine magnetic compass capable of being used as a steering compass:
MoMu0,1,2,3		a) <u>Permanently installed</u> marine magnetic steering compass, independent of any power supply, correctly adjusted with deviation card,
		b) a second compass which may be hand-held and/or electronic.
	3.25	Halyards
**	3.25.1	A minimum of two halyards, each capable of hoisting a sail, on each mast.
MoMu0,1,2,3	3.25.2	No halyard shall be locked, lashed, or otherwise secured to the mast in a way that requires a person to go aloft to lower a sail in a controlled manner, except for a headsail in use with a furling device.
	3.27	Navigation Lights
**	3.27.1	That conform to the International Regulations for Preventing Collisions at Sea (Part C and Technical Annex I) and shall be exhibited as required by those regulations.
**	3.27.2	Mounted above sheerline and so that they will not be masked by sails or the heeling of the boat.
MoMu0,1,2,3	3.27.3	Reserve lights having the same specifications as above, and that can be powered independently.
**	3.27.4	Spare bulbs (not required for LED).
	3.28	Engines, Generators, Fuel
	3.28.1	Propulsion Engines
**		a) engines and associated systems installed in accordance with their manufacturers' guidelines and suitable for the size and intended use of the boat,
MoMu0,1,2,3		b) an engine which provides a minimum speed in knots of $(1.8 \times \sqrt{L_{WL}}$ in metres) or $(\sqrt{L_{WL}}$ in feet),
Mo3		e) either an inboard or outboard engine, with associated power supply systems, all <u>securely fastened</u> ,
**		f) an inboard combustion engine shall have a <u>permanently installed</u> exhaust, cooling system, fuel supply, fuel tank(s) and shall have adequate heavy weather protection,
**		g) an inboard electrical engine, when fitted, shall be provided with a <u>permanently installed</u> power supply, adequate heavy weather protection and have an engine control system.
	3.28.2	Generator
**		If an optional generator separate from the propulsion engine is carried, it shall be installed in accordance with the manufacturer's guidelines.

SECTION 3 – STRUCTURAL FEATURES, STABILITY, FIXED EQUIPMENT

Categories	
	A boat shall be/have:
MoMu0,1,2,3	3.28.3 Liquid Fuel Systems
MoMu0,1,2,3	a) all fuel tanks for storage of liquid fuels shall be rigid (but may have <u>permanently installed</u> flexible linings) and shall have a shutoff valve,
	b) at the start a boat with a combustion engine shall carry sufficient fuel to meet charging requirements for the duration of the race and to motor at the above minimum speed for at least 5 hours.
**	3.28.4 Battery Systems
**	a) batteries installed after 2011 shall be of the sealed type from which liquid electrolyte cannot escape,
MoMu0,1,2,3	b) at the start a boat with an electric engine shall carry sufficient capacity to meet electrical requirements for the duration of the race and to motor at the above minimum speed for at least 5 hours.
	c) a dedicated engine/generator starting battery when an electric starter is the only method for starting the engine and/or separate generator,
Mo1,2,3	3.29 Communications Equipment, GNSS, Radar, AIS
Mu1,2,3,4	3.29.1 A hand-held marine VHF transceiver, with minimum 5 W output power , for each grab bag, watertight or with a waterproof cover. When not in use to be stowed in the grab bag (see <u>OSR</u> 4.21).
**	3.29.4 A second radio receiver, which may be the handheld VHF in <u>OSR</u> 3.29.1 above, capable of receiving weather bulletins.
MoMu0,1,2,3	3.29.5 A marine radio transceiver with an emergency antenna when the regular antenna depends upon the mast. Sail Canada prescribes that a boat shall have a VHF radio transceiver in accordance with 3.29.6.
MoMu0,1,2,3	3.29.6 If the marine radio transceiver is a VHF:
MoMu0,1,2,3	a) a minimum rated output power of 25 W,
MoMu1,2,3	b) if installed after 2015 be <u>DSC</u> capable,
MoMu3	e) a masthead antenna and co-axial feeder cable with not more than 40% power loss,
MoMu1,2,3	f) <u>DSC</u> capable VHF transceivers shall be programmed with an assigned MMSI (unique to the boat), be connected to a <u>GNSS</u> receiver and be capable of making distress alert calls as well as sending and receiving a <u>DSC</u> position report with another <u>DSC</u> equipped station,
MoMu3	h) if the number of <u>crewmembers</u> is fewer than 3, have an external speaker in the cockpit.
MoMu0,1,2,3	3.29.7 An <u>AIS</u> Transponder which either:
MoMu0,1,2,3	a) shares the masthead VHF antenna via a low loss <u>AIS</u> antenna splitter, or
MoMu0,1,2,3	b) has a dedicated <u>AIS</u> antenna not less than 38 cm (15”) in length mounted with its base not less than 3 m (10’) above the waterline and co-axial feeder cable with not more than 40% power loss.
MoMu3	3.29.8 A <u>GNSS</u> .

SECTION 4 – PORTABLE EQUIPMENT

Categories		A boat shall have:
	4.01	Sail Letters & Numbers
**	4.01.1	Identification on sails which complies with <u>RRS 77</u> and <u>RRS Appendix G</u> .
MoMu0,1,2,3	4.01.2	An alternative means of displaying identification as required under <u>RRS Appendix G</u> for a mainsail, to be displayed when none of the numbered sails are set.
	4.03	Soft Wood Plugs
**		A tapered soft wood plug stowed adjacent to every through-hull opening.
	4.04	Jackstays and Clipping Points
MoMu0,1,2,3	4.04.1	<u>Permanently Installed</u> fittings for <u>jackstay</u> ends and clipping points.
MoMu0,1,2,3	4.04.2	<u>Jackstays</u> which shall:
MoMu0,1,2,3		a) be independent on each side of the deck,
MoMu0,1,2,3		b) enable a <u>crewmember</u> to move readily between the working areas on deck and the cockpit(s) with the minimum of clipping and unclipping operations,
MoMu0,1,2,3		c) have a breaking strength of 2040 kg (4500#) and be uncoated and non-sleeved stainless steel 1 x 19 wire of minimum diameter 5 mm (3/16"), webbing or <u>HMPE</u> rope.
MoMu0,1,2,3	4.04.3	Clipping points which shall:
MoMu0,1,2,3		a) be adjacent to stations such as the helm, sheet winches and masts, where <u>crewmembers</u> work,
MoMu0,1,2,3		b) enable a <u>crewmember</u> to clip on before coming on deck and unclip after going below,
MoMu0,1,2,3		c) enable two-thirds of the crew to be simultaneously clipped on without depending on <u>jackstays</u> ,
	4.05	Fire Fighting Equipment
**	4.05.1	A fire blanket adjacent to every cooking device.
MoMu1,2,3	4.05.2	2 fire extinguishers, each with 2 kg of dry powder or equivalent, in different parts of the boat.
	4.06	Anchors
MoMu1,2,3	4.06.1	2 un-modified anchors that meet the anchor manufacturer's recommendation based on the boat's dimensions with suitable combination of chain and rope, ready for immediate assembly, and ready for deployment within 5 minutes except that for a boat less than 8.5 m (28') <u>L_H</u> there shall be 1 anchor meeting the same criteria.
	4.07	Flashlights and Searchlights
Mo0,1,2,3		Flashlights and searchlights need to be watertight (min IP67 rated), need to have spare batteries or be rechargeable, have spare bulbs or be an LED type, and need to provide at least 400 Lumens. The following need to be provided:
Mu0,1,2,3,4		a) a searchlight, suitable for searching for a person overboard at night and for collision avoidance,
MoMu0,1,2,3		b) stowed in each grab bag (see <u>OSR 4.21</u>), a flashlight.
Mo0,1,2,3		
Mu0,1,2,3,4		

SECTION 4 – PORTABLE EQUIPMENT

Categories		A boat shall have:
Mo0,1,2,3 Mu0,1,2,3,4		c) for boats with only two <u>crewmembers</u> , the searchlight detailed in 4.07 a) shall be accessible from the cockpit without having to go below deck.
**	4.08	First Aid Manual and First Aid Kit A First Aid Manual and First Aid Kit. The contents and storage of the First Aid Kit shall reflect the likely conditions and duration of the passage, and the number of <u>crewmembers</u> .
**	4.09	Foghorn A foghorn.
**	4.10	Radar Reflector
**	4.10.1	A passive radar reflector with:
**		a) octahedral circular plates of minimum diameter 30 cm (12”),
**		b) octahedral rectangular plates of minimum diagonal dimension 40 cm (16”), or
**		c) a non-octahedral reflector with a documented root mean square minimum Radar Cross Section (RCS) area of 2 m ² (22 ft ²) from 0–360° of azimuth and ±20° of heel.
MoMu0,1,2,3	4.11	Navigation Equipment
	4.11.1	Navigational charts (not solely electronic) and chart plotting equipment.
**	4.12	Safety Equipment Location Chart A safety equipment location diagram in durable waterproof material, clearly displayed in the main accommodation, marked with the location of principal items of safety equipment.
MoMu0,1,2,3	4.13	Depth, Speed and Distance Instruments
MoMu1,2,3,4	4.13.1	A knotmeter or distance measuring instrument (log).
	4.13.2	A depth sounder.
MoMu0,1,2,3	4.15	Emergency Steering
MoMu0,1,2,3	4.15.1	An emergency tiller capable of being fitted to the rudder stock except when:
MoMu0,1,2,3		a) the principal method of steering is by means of an unbreakable metal tiller,
MoMu0,1,2,3		b) there are two methods (e.g. tillers, wheels) of controlling a rudder, neither of which shares components with the other except for the rudder stock.
MoMu0,1,2,3	4.15.2	A proven method of emergency steering with the rudder disabled.
**	4.16	Tools and Spare Parts
**	4.16.1	Tools and spare parts, suitable for the duration and nature of the passage.
**	4.16.2	An effective means to quickly disconnect or sever the standing rigging from the boat.
**	4.17	Boat’s Name The boat’s name on miscellaneous buoyant equipment, such as lifejackets, cushions, lifebuoys, recovery slings, grab bags, etc.
**	4.18	Retro-Reflective Material Marine grade retro-reflective material on lifebuoys, recovery slings, liferafts and lifejackets.

SECTION 4 – PORTABLE EQUIPMENT

Categories		A boat shall have:
	4.21	Grab Bags
Mo0,1,2,3 Mu0,1,2,3,4	4.21.1	A grab bag shall have inherent flotation, at least 0.1 m ² (1 ft ²) area of highly visible colour (e.g. dayglo yellow or orange) on the outside, shall be marked with the name of the boat, and shall have a lanyard and clip. If a grab bag has to accompany a specific life raft, it shall be clearly marked with the identity of its corresponding raft.
Mo3	4.21.4	The following shall either be stowed with a liferaft or a in grab bag. The grab bag shall be readily accessible whether or not the boat is inverted:
Mo3Mu3,4 Mo3Mu3,4 Mo3Mu3,4 Mo3Mu3,4		<ul style="list-style-type: none"> a) 3 hand flares, b) watertight strobe light with spare batteries (may be part of the flashlight), c) knife, and d) whistle.
	4.22	Crew Overboard Identification and Recovery
	4.22.2	GNSS Crew Overboard Position
MoMu1,2,3		a) For boats with only two <u>crewmembers</u> , a GNSS capable of recording a crew overboard position, within 10 seconds, and monitoring that position without having to go below deck.
	4.22.3	Lifebuoys
MoMu3,4 **		<ul style="list-style-type: none"> a) a lifebuoy with a self-igniting light, a whistle, and a drogue within reach of the helmsman and ready for immediate use, e) each inflatable lifebuoy and any automatic device shall be tested and serviced at intervals in accordance with its manufacturer’s instructions.
	4.22.4	Heaving Line
**		A heaving line, no less than 6 mm (1/4”) diameter, 15–25 m (50–75’) long, readily accessible to cockpit.
	4.22.5	Recovery Sling
MoMu0,1,2,3 MoMu0,1,2,3 MoMu0,1,2,3 MoMu0,1,2,3		A recovery sling which includes a: <ul style="list-style-type: none"> a) buoyant line of length no less than the shorter of 4 times L_H or 36m (120’), b) buoyancy section (horseshoe) with no less than 90 N (20#) buoyancy, c) minimum strength capable to hoist a <u>crewmember</u> aboard.
	4.23	Pyrotechnic and Light Signals
**		Pyrotechnic signals shall be provided conforming to <u>LSA</u> Code Chapter III Visual Signals and not older than the stamped expiry date (if any) or if no expiry date stamped, not older than 4 years:
** MoMu0,1,2,3		<ul style="list-style-type: none"> a) 2 orange smoke <u>LSA</u> III 3.3, b) 4 red hand flares <u>LSA</u> III 3.2.
	4.25	Cockpit Knife
**		A strong, sharp knife, in a securely restrained sheath shall be readily accessible from the deck or a cockpit.
	4.26	Storm & Heavy Weather Sail Inventory
**		the following storm & heavy weather sails as specified in <u>OSR</u> 4.27:

SECTION 4 – PORTABLE EQUIPMENT

Categories		A boat shall have:
MoMu3	4.26.3	either a storm trysail or mainsail reefing to reduce the luff by at least 40% (or rotating wing mast if suitable),
MoMu0,1,2,3	4.26.5	heavy weather jib,
	4.27	Storm & Heavy Weather Sail Specifications
		Where required by <u>OSR</u> 4.26, the specifications of heavy weather sails shall follow:

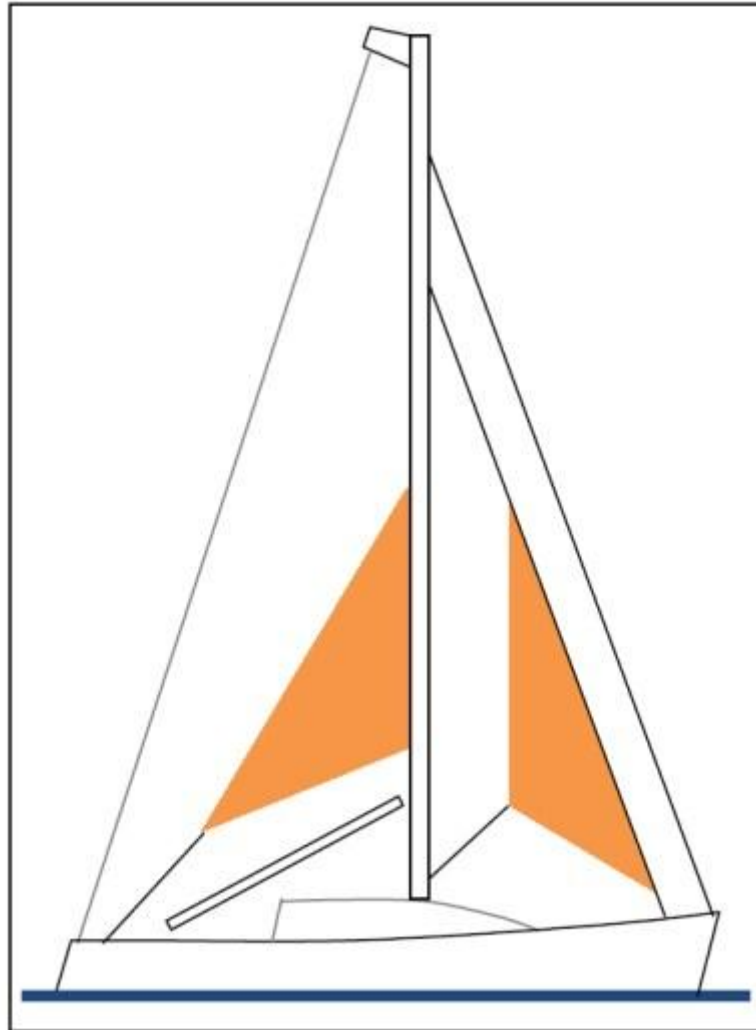

Figure 3 – Storm Sails

[4.27.1](#) Design

- ** a) the material of the body of a storm sail purchased after 2013 shall have a highly visible colour (e.g. dayglo pink, orange or yellow),
- ** b) aromatic polyamides, carbon and similar fibres shall not be used in a trysail or storm jib, but HMPE and similar materials are permitted,
- ** c) sheeting positions on deck for each storm and heavy-weather sail,
- ** d) sheeting positions for the trysail independent of the boom, and
- ** e) A storm jib may not be set in conjunction with any other sail set forwards of the forward **mast** spar.

SECTION 4 – PORTABLE EQUIPMENT

Categories	A boat shall have:
	4.27.2 A Storm Trysail with:
MoMu0,1,2,3	a) area not greater than 17.5% mainsail hoist (P) x mainsail foot length (E),
MoMu0,1,2,3	b) the storm trysail area shall be calculated as (0.5 x leech length x shortest distance between tack point and leech),
MoMu0,1,2,3	c) no headboard,
MoMu0,1,2,3	d) no battens,
MoMu0,1,2,3	e) sail number and letters on both sides, as large as practicable,
MoMu1,2,3	f) in the case of a boat with an in-mast furling mainsail, the storm trysail shall be capable of being set while the mainsail is furled, and
MoMu0,1,2,3	g) designed to provide propulsion and steerage in Beaufort scale 8 and on all points of sail.
	4.27.3 A Heavy Weather Jib (or Heavy Weather Sail in a Boat with no Forestay) with:
**	a) area, in unreefed condition, not greater than 13.5% height of the foretriangle squared,
**	b) heavy weather jib area shall be calculated as: (0.255 x luff length x (luff perpendicular + 2 x half width)),
**	c) readily available method, independent of a luff groove, to attach to the stay, and
**	d) designed to provide propulsion and steerage in Beaufort scale 6 and on all points of sail.

SECTION 5 – PERSONAL EQUIPMENT

Categories		Each <u>crewmember</u> shall have:
**	5.01	Lifejacket
**		Sail Canada prescribes:
**		a gas inflatable lifejacket manufactured after 2011, with at least 150N buoyancy, compliant with either UL1180 or UL1180C, and which shall be fitted with items a) through e) below, each equivalent to or complying with ISO 12402-3 or ISO 12402-8:
**		or
**	5.01.1	A gas inflatable lifejacket which shall comply with <u>ISO</u> 12402-3 (Level 150) and have been manufactured after 2011. It shall be fitted with the following, each complying with <u>ISO</u> 12402-3 or <u>ISO</u> 12402-8:
**		Sail Canada note – ISO 12402 is not currently approved by Transport Canada.
**		a) a manual or automatic gas inflation system,
**		Sail Canada prescribes:
**		• a whistle secured by a cord or line
**		• retro-reflective material
**		b) a ride up prevention system (crotch strap or thigh straps),
MoMu0,1,2,3		c) an emergency position indicating light,
MoMu0,1,2,3		d) a sprayhood,
MoMu3		It shall also:
MoMu0,1,2,3		e) a deck safety harness (attachment),
MoMu0,1,2,3		Sail Canada prescribes:
MoMu0,1,2,3		• that is integrated with the lifejacket and complies with <u>OSR</u> 5.02
**		g) be of the appropriate size range for the <u>crewmember</u> as marked on the PFD, and
**		h) have been indelibly marked with the name of the owner or boat.
MoMu0,1,2,3	5.01.2	A boat shall carry at least one gas inflatable lifejacket spare cylinder and, if appropriate, spare activation head for each type of lifejacket on board.
**	5.01.4	The <i>person in charge</i> shall personally check that each lifejacket has been serviced in accordance with the manufacturer’s recommendation by an approved service station and that the next service date as marked on the lifejacket has not been exceeded.
**		Sail Canada prescribes that where the manufacturer permits the lifejacket owner/user to perform the recommended service, the owner/user is considered to be an approved service station.
	5.02	Deck Safety Harness and Tethers
MoMu0,1,2,3	5.02.1	A harness that complies with <u>ISO</u> 12401 or equivalent.
MoMu0,1,2,3	5.02.2	A <u>tether</u> that shall:
MoMu0,1,2,3		a) comply with <u>ISO</u> 12401 or equivalent,
MoMu0,1,2,3		b) not exceed 2 m (6’-6”) including the length of the hook(s),
MoMu0,1,2,3		c) have self-closing hook(s),
MoMu0,1,2,3		d) have overload indicator flag embedded in the stitching, and

SECTION 5 – PERSONAL EQUIPMENT

Categories		Each <u>crewmember</u> shall have:
MoMu0,1,2,3		e) be manufactured after 2000.
MoMu0,1,2,3	5.02.3	either:
MoMu0,1,2,3		a) a <u>tether</u> not exceeding 1 m (3'-3") including the length of the hook(s), or
MoMu0,1,2,3		b) an intermediate self-closing hook on a 2 m (6'-6") <u>tether</u> .
MoMu0,1,2,3	5.02.5	A <u>tether</u> which has been overloaded shall be replaced.

SECTION 6 – TRAINING

Categories	6.01	Training
MoMu3	6.01.3	Sail Canada prescribes that at least 30% but not fewer than two <u>crewmembers</u> , including the <i>person in charge</i> shall have a Sail Canada-accredited Coastal Personal Survival Training course, or training accepted as equivalent by the <i>organizing authority</i> , within the five years before the start of the race.
MoMu0,1,2,3	6.01.5	A refresher course may be taken to renew a certificate if the refresher course is completed within 2 years of the expiration of the individual’s most recent Offshore Personal Survival Course certificate.
	6.02	Training Topics
MoMu0,1,2,3	6.02.1	Giving Assistance to Other Craft
MoMu0,1,2,3	6.02.2	Personal Safety Gear, theory and practice
MoMu0,1,2,3	6.02.3	Care and Maintenance of Safety Gear
MoMu0,1,2,3	6.02.4	Fire Precautions and Firefighting, theory and practical
MoMu0,1,2,3	6.02.5	Crew Overboard Prevention and Recovery
MoMu0,1,2,3	6.02.6	Hypothermia, Cold Shock and Drowning
MoMu0,1,2,3	6.02.7	Crew Health
MoMu0,1,2,3	6.02.8	Marine Weather
MoMu0,1,2,3	6.02.9	Heavy Weather
MoMu0,1,2,3	6.02.10	Storm Sails
MoMu0,1,2,3	6.02.11	Damage Control
MoMu0,1,2,3	6.02.12	Search and Rescue Organisation
MoMu0,1,2,3	6.02.13	Pyrotechnics and Signalling Gear, theory and practical
MoMu0,1,2,3	6.02.14	Emergency Communications, theory and practical
MoMu0,1,2,3	6.02.15	Liferafts and Abandon Ship, theory and practical
	6.04	Routine Training Onboard
**		At least annually the crews shall practice the drills for:
**		a) crew-overboard recovery, and
**		b) abandonment of vessel.
	6.05	Medical Training
MoMu3,4	6.05.3	At least two <u>crewmembers</u> shall be familiar with First Aid procedures, hypothermia, drowning, cardio-pulmonary resuscitation, and relevant communications systems.



APPENDIX F – Inspection Card

For Monohull Category 3

JANUARY 2026 – DECEMBER 2027

© ORC Ltd. 2002, amendments 2003-2026 © World Sailing



Instructions

- **PERSON IN CHARGE** (see Racing Rules of Sailing 46): please fill in this form, prepare the boat, initial above each underline and sign where indicated.
- **INSPECTORS** mark each inspected item with a checkmark or cross. Note any deficiencies on the Deficiency Report. Show the Deficiency Report to the *Person in Charge*, then return the report to the Race Committee as soon as possible.

Boat _____

Sail Number _____

No of persons on board _____

Disclaimer of Liability The inspection is carried out as a courtesy. An inspector cannot limit or reduce the complete and unlimited responsibility of the owner and the person in charge.

"I hereby declare that I am the *Person in Charge*, that wherever I initial an item on this checklist it conforms to its associated Offshore Special Regulations (OSR), that I have read and understand the OSRs and in particular [1.02.1](#) and [1.02.2](#)

Signed _____ Date _____

Printed Name _____

Note: PURPLE text indicates additional requirements to category 4

Precedence: The checklist below is in point form. In all cases the full text in the Offshore Special Regulations takes precedence.

Inspector only ↓

Person in Charge initials here ↓

Lay out on Chart Table or Other Surface

- | | | | |
|------------------------|---|-------|--------------------------|
| 3.04.1 | Proof that boat meets ISO 12217-2 category B or equivalent stability | _____ | <input type="checkbox"/> |
| 4.11.1 | Charts (not solely electronic), plotting equipment | _____ | <input type="checkbox"/> |
| 6.01.3 | Approved survival training certificates for 30% of the crew (minimum 2) | _____ | <input type="checkbox"/> |
| 6.04 | Proof that crew-overboard recovery has been practiced within past year | _____ | <input type="checkbox"/> |
| 6.04 | Proof that abandonment of vessel has been practiced within past year | _____ | <input type="checkbox"/> |
| 6.05.3 | 2 crewmembers familiar with 1st Aid, CPR & communication systems | _____ | <input type="checkbox"/> |

Lay out on Bunk(s)

APPENDICES F – INSPECTION CARD

3.29.4	2nd radio capable of receiving weather, could be the handheld VHF	_____	<input type="checkbox"/>
3.29.5	Emergency antenna for each type of installed radio transceiver	_____	<input type="checkbox"/>
4.08	First Aid Manual and First Aid Kit	_____	<input type="checkbox"/>
4.09	Foghorn	_____	<input type="checkbox"/>
4.16.1	Tools, spare parts, method to disconnect/sever standing rigging	_____	<input type="checkbox"/>
4.23	Flares, 4 red hand-held and 2 orange smoke, LSA III	_____	<input type="checkbox"/>
5.01	Lifejacket c/w lights, whistle etc., 1 for each crew, marked with name	_____	<input type="checkbox"/>
5.01.2	Spare cylinder and activation head for each type on board	_____	<input type="checkbox"/>
5.01.4	Each lifejacket inspection does not exceed service date	_____	<input type="checkbox"/>
5.02.1	Deck safety harness for each crewmember	_____	<input type="checkbox"/>
5.02.2	2 m (6'-6") tether, with coloured overload flag, for each crewmember	_____	<input type="checkbox"/>
5.02.3	Mid-tether hook on 2 m tether, or 1 m (3'-3") tether for each crewmember	_____	<input type="checkbox"/>
Grab Bag			
3.29.1	Watertight handheld VHF radio transceiver stowed in each grab bag	_____	<input type="checkbox"/>
4.07	Watertight (IP67) flashlight with spare batteries and bulbs	_____	<input type="checkbox"/>
4.21.1	Grab bag for each raft, with inherent flotation and 0.1 m ² (1 ft ²) bright colour	_____	<input type="checkbox"/>
4.21.4	3 hand flares	_____	<input type="checkbox"/>
4.21.4	Watertight strobe light	_____	<input type="checkbox"/>
4.21.4	Knife	_____	<input type="checkbox"/>
4.21.4	Whistle	_____	<input type="checkbox"/>
Below Deck Inspection			
3.06	2 exits, at least 1 forward of the foremost mast	_____	<input type="checkbox"/>
3.08.3	Portlights that open inward labelled "NOT TO BE OPENED AT SEA"	_____	<input type="checkbox"/>
3.10	Sea cocks or valves on through-hull openings below waterline	_____	<input type="checkbox"/>
3.12	Heel of keel-stepped mast is securely fastened to structure	_____	<input type="checkbox"/>
3.18.2	Toilet, permanently installed, or fitted bucket	_____	<input type="checkbox"/>
3.19.1	Bunks, permanently installed	_____	<input type="checkbox"/>
3.20	Cooking stove, permanently installed, with fuel shut-off	_____	<input type="checkbox"/>
3.21.1	Sufficient drinking water (in water tank or reusable containers)	_____	<input type="checkbox"/>

APPENDICES F – INSPECTION CARD

3.21.3	Emergency drinking water 2 L (0.5 US Gal) per person	_____	<input type="checkbox"/>
3.22	Hand holds below deck	_____	<input type="checkbox"/>
3.27.4	Spare bulbs for navigation lights (not required for LED)	_____	<input type="checkbox"/>
3.28.4	Batteries are of sealed type	_____	<input type="checkbox"/>
3.28.4	Separate engine starting battery or hand-starting device	_____	<input type="checkbox"/>
3.29.6	25W DSC enabled VHF w/ masthead antenna & programmed MMSI	_____	<input type="checkbox"/>
3.29.7	AIS Transponder w/ shared masthead or raised dedicated antenna	_____	<input type="checkbox"/>
4.03	Tapered soft wood plug at each through-hull opening	_____	<input type="checkbox"/>
4.05.1	Fire blanket adjacent to every cooking device	_____	<input type="checkbox"/>
4.05.2	2 fire extinguishers, 2 kg each in different parts of the boat	_____	<input type="checkbox"/>
4.12	Safety equipment location chart	_____	<input type="checkbox"/>
At Helm or Ready for Immediate Deployment			
4.22.2	For double handed, GNSS to track crew overboard from on deck	_____	<input type="checkbox"/>
4.22.3	Lifebuoy with self-igniting light, whistle and drogue	_____	<input type="checkbox"/>
4.22.4	Heaving line, pref. 'Throwing sock' type, 6mm (1/4") 15–25m (50–75')	_____	<input type="checkbox"/>
4.22.5	Recovery Sling (Lifesling® or equivalent)	_____	<input type="checkbox"/>
4.25	Strong, sharp knife, sheathed and securely restrained	_____	<input type="checkbox"/>
On Deck, Where Stowed or Ready for Deployment			
3.08.4	Hatch blocking devices (panels) attached and can be secured in place	_____	<input type="checkbox"/>
4.06.1	2 suitably sized anchors and rode ready for immediate use	_____	<input type="checkbox"/>
4.07	Watertight (IP67) searchlight to find person overboard or collision avoidance	_____	<input type="checkbox"/>
Rigged/Fitted to Demonstrate Use			
3.27.1	Navigation lights, above sheerline and not obscured when sailing	_____	<input type="checkbox"/>
3.27.3	Reserve navigation lights, can be powered separately	_____	<input type="checkbox"/>
4.01.2	Alternate method for displaying sail letters and numbers	_____	<input type="checkbox"/>
4.04.2	Jack stays are independent on each side of the deck	_____	<input type="checkbox"/>
4.04.2	Jack stays to permit crew to move between workstations while clipped	_____	<input type="checkbox"/>
4.04.3	Clipping points at workstations so that 2/3 can clip on without jack stays	_____	<input type="checkbox"/>
4.10.1	Radar reflector, 30 cm (12") dia. octahedral or minimum RCS of 2 m ²	_____	<input type="checkbox"/>

APPENDICES F – INSPECTION CARD

4.15.1	Emergency tiller	_____	<input type="checkbox"/>
4.15.2	Proven method of emergency steering with the rudder disabled	_____	<input type="checkbox"/>
4.26.3	Either a storm trysail or reefing to reduce mainsail luff by 40%	_____	<input type="checkbox"/>
4.26.5	Heavy weather jib, attachable independent of luff groove	_____	<input type="checkbox"/>
4.27.1	Sheeting positions for each heavy/storm sail	_____	<input type="checkbox"/>
	General		
2.04	All equipment is readily available, adequately sized, in date and functions	_____	<input type="checkbox"/>
2.04.2	Heavy items are permanently installed or securely fastened	_____	<input type="checkbox"/>
3.02	Boat is strongly built, seaworthy and watertight	_____	<input type="checkbox"/>
3.02.4	Keel and rudder were inspected within past 2 years	_____	<input type="checkbox"/>
3.08.1	Forward hatches open outward only	_____	<input type="checkbox"/>
3.08.2	Hatches are attached, above water at 90° heel & operable if capsized	_____	<input type="checkbox"/>
3.08.5	Companionway sill is above local sheerline, or acceptable alternative	_____	<input type="checkbox"/>
3.09.1	Cockpit is strong, watertight and meets OSR size and drainage	_____	<input type="checkbox"/>
3.14	Double lifelines & pulpits, surround entire deck, 600 mm (24") high	_____	<input type="checkbox"/>
3.14.3	Lifeline materials and diameters meet OSR	_____	<input type="checkbox"/>
3.17.1	25 mm (1") toe rail around foredeck	_____	<input type="checkbox"/>
3.23.1	2 strong buckets, each with lanyard and 9 L (2.4 US Gal) capacity	_____	<input type="checkbox"/>
3.23.1	Permanently installed manual bilge pump	_____	<input type="checkbox"/>
3.23.2	Permanently installed manual bilge pump operable with all hatches closed	_____	<input type="checkbox"/>
3.24	Magnetic compass, unpowered, with deviation chart	_____	<input type="checkbox"/>
3.24	2nd magnetic compass, may be hand-held and/or electronic	_____	<input type="checkbox"/>
3.25	2 halyards per mast, each capable of hoisting a sail	_____	<input type="checkbox"/>
3.28.1	Propulsion engine provides minimum speed of 3/4 hull speed	_____	<input type="checkbox"/>
3.28.1	Inboard or outboard propulsion engine	_____	<input type="checkbox"/>
3.28.3	Fuel or battery capacity to motor at 3/4 hull speed for 5 hours+ house needs	_____	<input type="checkbox"/>
3.29.6	External VHF speaker in cockpit	_____	<input type="checkbox"/>
3.29.8	GNSS	_____	<input type="checkbox"/>
4.01.1	Sail letters and numbers meeting RRS 77 & RRS G	_____	<input type="checkbox"/>

APPENDICES F – INSPECTION CARD

- | | | | |
|------------------------|---|-------|--------------------------|
| 4.13.1 | Knotmeter or log | _____ | <input type="checkbox"/> |
| 4.13.2 | Depth sounder | _____ | <input type="checkbox"/> |
| 4.17 | Boat's name on buoyant equipment | _____ | <input type="checkbox"/> |
| 4.18 | Marine grade retro-reflective material on buoyant equipment | _____ | <input type="checkbox"/> |