



# J/70 North American Championship & Winter Series Event #1



Davis Island Yacht Club - Tampa, FL - USA  
Dec 01-06, 2025

## SAILING INSTRUCTIONS

The Organizing Authority (OA) is the DIYC and the International J/70 Class Association (IJ70CA).

Event Website: <https://www.yachtscore.com/emenue/50327>

See SI 29 for full contact information

*The notation '[NP]' in a rule means that a boat may not protest another boat or request redress for a violation of that rule. This changes RRS 60.1.*

### 1. RULES

- 1.1 NoR 1 contains a list of rules for this event. Competitors are reminded to take note of these.
- 1.2 J70 RR 13.1 shall not apply.
- 1.3 [NP] The RRS changes for using the Vakaros RaceSense system are identified in **Addendum RS**.
- 1.4 RRS 60.4(a)(2) is changed as follows: "(2) if it alleges a breach of a rule of Part 2 or rule 31 and is from a boat that was not involved in, **and** did not see, the incident, or".

### 2. CHANGES TO SAILING INSTRUCTIONS

Any change to the SIs will be posted before 0900 on the day it will take effect, except that any change to the schedule of races will be posted by 2000 on the day before it will take effect.

### 3. COMMUNICATION

- 3.1 Notices to competitors will be posted on the Official Notice Board located on the event website list above. Unofficial but informative information will be sent out on the "DIYC J/70 Winter Series" WhatsApp group (**Addendum E** contains the QR code to join that group).
- 3.2 The race office is located in the downstairs classroom below the main DIYC dining room.
- 3.3 Any questions regarding the NoR or these SIs shall be submitted in writing to the Race Committee (RC). The questions and any answers will be posted as in SI 3.1.
- 3.4 A competitors' briefing will be held each race day at 0900 upstairs in the DIYC clubhouse.
- 3.5 On the water, the RC intends to monitor and communicate with competitors on VHF radio channel 72 ('the VHF Channel'). Failure of the RC to broadcast, mistaken broadcasts, or failure of a competitor to receive this information will not be grounds for a request for redress. This changes RRS 60.1.
- 3.6 [NP] [DP] Boats shall use the radio to report retirement from racing and may use the radio to request or provide assistance in an emergency.
- 3.7 [DP] Except as provided in SI 3.6, a boat shall not make voice or data transmissions while racing and shall not receive voice or data communication that is not available to all boats.
- 3.8 [NP] A messaging service may be used to provide supplementary communications. See QR code in **Addendum E**.

#### 4. CODE OF CONDUCT

- 4.1 [DP] Competitors and support persons shall comply with reasonable requests from race officials.
- 4.2 [DP] Competitors and support persons shall handle any equipment provided by the organizing authority with care, seamanship, in accordance with any instructions for its use and without interfering with its functionality.

#### 5. SIGNALS MADE ASHORE

- 5.1 Signals made ashore will be displayed on the DIYC flagpole located on the west end of the property.
- 5.2 When flag AP is displayed ashore, "1 minute" is replaced with "not less than forty-five (45) minutes" in The Racing Rules of Sailing (RRS) Race Signal AP.

#### 6. SCHEDULE AND FORMAT OF RACES

##### 6.1 Race Schedule

Day	Races Planned	First Warning Signal
Tuesday, December 02	1 or more practices race(s)	1430
Wednesday, December 03	2 or 3 races	1100
Thursday, December 04	2 or 3 races	1100
Friday, December 05	2 or 3 races	1100
Saturday, December 06	2 or 3 races	1100 (no warning signal after 1430)

- 6.2 Up to ten (10) races are scheduled. A maximum of three (3) races may be sailed in one day. The RC, at its discretion, may run fewer total races. Additionally, at the discretion of the RC, four (4) races may be sailed in any day to maintain the overall regatta schedule.
- 6.3 The scheduled time of the first warning signal each day is 1100. Subsequent races will start as soon as practicable.
- 6.4 On Saturday, December 06, no warning signal will be made after 1430 local time. In the case of one or more general recall(s) when the initial warning signal was made prior to 1430, the RC may make subsequent warning signals after that time. This exception will not apply for a race that is postponed or abandoned.
- 6.5 All boats shall sail as one fleet.

#### 7. CLASS FLAG

The class flag is a blue J/70 logo on a white background or numeral pennant 1.

#### 8. RACING AREA

**Addendum A** shows the location of the racing area.

#### 9. COURSES

- 9.1 The course to be sailed will be a windward-leeward format. The diagrams in **Addendum B** show the course, including the order in which marks are to be passed, and the side on which each mark is to be left.
- 9.2 No later than the warning signal for each race, the RC signal vessel will use placards to identify the approximate magnetic bearing and distance to the first weather mark. Or announce the bearing and distance over the VHF Channel.
- 9.3 Courses will not be shortened using flag "S". This changes RRS 32. However, legs of the course may be shortened (or lengthened) pursuant to RRS 33.

## 10. MARKS

- 10.1 All marks are autonomous marks which will go back to their original position if they are dragged or otherwise moved off station. Routine movement of autonomous marks will not be grounds for redress. This includes minor readjustments and marks returning to station after having been pushed or dragged away by a competitor.
- 10.2 Mark 1 will be an orange autonomous mark and Mark 1A (offset) will be a green autonomous mark.
- 10.3 Marks 2S/2P (gate) will be yellow autonomous marks.
- 10.4 All change marks will be the original mark(s).
- 10.5 Starting and finishing marks are the RC signal vessel and will be a yellow autonomous mark.

## 11. THE START

- 11.1 The starting line is between a Vakaros device mounted to the staff displaying an orange flag on the RC signal vessel and a Vakaros device mounted to a pole displaying an orange flag on the starting mark.
- 11.2 A boat that does not start within five (5) minutes after her starting signal will be scored Did Not Start (DNS) without a hearing. This change is added to RRS A5.1.

## 12. CHANGING THE NEXT LEG OF THE COURSE

- 12.1 To change the next leg of the course, the RC will move the original mark as soon as practicable.
- 12.2 The RC can adjust the course up to 10 degrees and 0.1nm without signaling a course change. They will announce this change on the VHF Channel. This is added to RRS 33.

## 13. THE FINISH

- 13.1 The finish line is between a Vakaros device mounted to the staff displaying an orange flag on the RC signal vessel and a Vakaros device mounted to a pole displaying an orange flag on the finishing mark. This changes Race Signals Blue flag.
- 13.2 Unless Addendum RS.9 applies, the Vakaros RaceSense system will be used by the Race Committee at the finishing line.

## 14. PENALTY SYSTEM

- 14.1 The first sentence of RRS 44.1 is changed to "A boat may take a One-Turn Penalty when she may have broken one or more rules of Part 2 in an incident while racing, except that when she may have broken a rule of Part 2 while in the zone around a mark other than a starting mark, her penalty shall be a Two-Turns Penalty."
- 14.2 Penalties incurred while in the zone of the windward mark or on the offset leg shall be delayed and taken at the first reasonable opportunity on the downwind leg. This change is added to RRS 44.2.
- 14.3 RRS Appendix P (Special Procedures for Rule 42) is in effect and replaced in its entirety as stated in **Addendum C**.
- 14.4 Jury vessels may be positioned anywhere on the course area. Their position at any time will not be grounds for a request for redress. This changes RRS 61.1(a).
- 14.5 RRS Appendix T (Arbitration) applies.
- 14.6 The IJ may impose discretionary penalties other than disqualification for violations of RRS non-Part 2 rules. This SI does not apply to breaches of RRS 2, 28 or 31.
- 14.7 The IJ may impose discretionary penalties other than disqualification for violations of Class Rules, including the International J/70 Class Rules (J70CR) and the J/70 Equipment Regulations (J70ER). However, in no case shall the penalty for such a violation be less than a ten percent (10%) scoring penalty calculated pursuant to RRS 44.3(c). This changes RRS 64.

## 15. TIME LIMITS AND TARGET TIMES

- 15.1 The race time limit for each race is 75 minutes. The target time for each race is 45-60 minutes. Failure to meet the target time will not be grounds for a request for redress. This changes RRS 61.1(a).
- 15.2 Boats failing to finish within 20 minutes after the first boat sails the course and finishes within the race time limit will be scored Time Limit Expired (TLE) without a hearing, unless they subsequently retire, are penalized, or are given redress. The score for TLE is the number of finishers plus two points, but no worse than the score for DNF. This changes RRS 35 and is added to RRS A4, A5, and A10.
- 15.3 The RC will lower the signal vessel finish line flag with one sound to indicate that the time limit in SI 15.2 has expired.

## 16. HEARING REQUESTS

- 16.1 The jury desk and the hearing room will be located in the downstairs classroom below the main DIYC dining room.
- 16.2 The protest time limit each day is sixty (60) minutes after the RC signal vessel docks on that day. This time will be posted on the Official Notice Board and at the jury desk within fifteen (15) minutes after the RC signal vessel docks.
- 16.3 The second sentence of RRS 61.2(b)(1) is replaced with: "If the request is based on an incident in the racing area, it shall be filed within the protest time limit for that day."
- 16.4 A notice of boats scored per RRS A5.1 and SI **Addendum C** each day will be posted on the Official Notice Board and at the jury desk no later than fifteen (15) minutes after the RC signal vessel docks on that day. The deadline for a request for redress based on these scores is the protest time limit for that day. This changes RRS 61.2.
- 16.5 The time limit for a request for redress based on the outcome of a scoring inquiry is 30 minutes after that outcome has been posted. This changes RRS 61.2(b)(1).
- 16.6 The Categorization Protest Time Limit (see World Sailing Regulation 22.5.1) is the protest time limit for the first racing day.
- 16.7 Hearing request forms are available at the jury desk or on the regatta website.
- 16.8 Penalty acceptance forms are available at the jury desk or on the regatta website.
- 16.9 Notices will be posted no later than fifteen (15) minutes after the protest time limit each day on the Official Notice Board and at the jury desk to inform competitors of hearings in which they are parties or named as witnesses. Hearings will be heard as soon as possible.

## 17. SCORING

- 17.1 Scoring shall be according to the Low Point Scoring System of RRS A2 and A4 as follows:
  - (a) When fewer than five (5) races have been completed, a boat's series score shall be the total of her race scores;
  - (b) When five (5) or more races have been completed, a boat's series score shall be the total of her race scores excluding her worst score.
- 17.2 Three (3) races are required to constitute a championship.
- 17.3 Preliminary results will be posted on the event website as soon as possible after racing each day.
- 17.4 Competitors shall notify the RC of any scoring inquiry by filing a Scoring Inquiry Form available at the jury desk or the regatta website. The deadline to file a scoring inquiry is the protest time limit or thirty (30) minutes after the preliminary results have been posted for that day, whichever is later.

## 18. SAFETY REGULATIONS

- 18.1 [DP] [NP] Prior to the warning signal of her first race each day, each boat shall check-in with the RC signal vessel in the starting area. Each boat shall pass close astern on starboard tack and hail her sail number. When a boat has been recognized, the RC will hail the boat's sail number.
- 18.2 [DP] [NP] A boat that retires from a race or leaves the racing area between races shall notify the RC as soon as possible using the VHF Channel.
- 18.3 [DP] [NP] A boat not leaving the harbor for any of the day's racing shall inform the RC as soon as possible.
- 18.4 The penalty for breaking a rule in SI 18 shall be a twenty percent (20%) scoring penalty calculated pursuant to RRS 44.3(c) unless the Jury decides differently, applied without a hearing to a boat's first valid race of the day. This change is added to RRS A5.1.

## 19. BOW NUMBERS [NP]

- 19.1 **If supplied and assigned**, bow numbers shall be applied in accordance with the J70ER 6 and J70ER Appendix A as shown in **Addendum D**.
- 19.2 **If supplied and assigned**, bow numbers shall be displayed from the time they are applied through the end of the event. It is the responsibility of the competitor to ensure that the bow numbers remain on the boat and obtain replacements as necessary.

## 20. REPLACEMENT OF CREW OR EQUIPMENT

- 20.1 Substitution of competitors is not allowed without written approval of the event Technical Committee prior to racing on that day.
- 20.2 Repair, alteration, replacement, or substitution of damaged or lost equipment will not be allowed unless authorized before racing by the event Technical Committee pursuant to J70ER 10.
- 20.3 Boats requesting approvals under SI 20 shall contact the event Technical Committee for instructions:
- (a) If off the water: by phone, text message, or WhatsApp (see SI 29 for contact information);
  - (b) If on the water: hailing on the VHF Channel.

## 21. EQUIPMENT AND MEASUREMENT CHECKS

[DP] Pursuant to J70ER 4, a boat, sails or equipment may be inspected at any time for compliance with the Event Equipment Rules (see J70ER 2), IJ70CA Class Rules (J70CR), the NoR and these SIs. On the water, when instructed by a member of the RC or event Technical Committee, a boat shall proceed immediately to a designated area for inspection.

## 22. EVENT ADVERTISING

- 22.1 [DP] [NP] Boats shall display any event advertising supplied by the OA, in accordance with World Sailing Regulation 20. If this rule is broken, World Sailing Regulation 20.9.2 applies.
- 22.2 [DP] [NP] Any required sponsor or event identification stickers, decals and flags shall be placed on the bow or boom, in the cockpit or on a shroud or stay as directed by the OA. They shall be displayed from the close of check-in through the end of the event. If required to be placed on the bow, they shall be placed immediately aft of the bow numbers. It is the responsibility of the competitor to ensure that the stickers remain on the boat and obtain replacements as necessary.

## 23. OFFICIAL VESSELS

[NP] Official vessels may be marked as follows:

Category	Flag
Jury Vessels	"Judges" flag or code flag J

## 24. SUPPORT TEAMS

- 24.1 [DP] [NP] Only registered Support Person Vessels (SPVs), including coach, press, private and spectator vessels that prominently display identification provided by the OA are allowed in the racing area. The person in charge of the competing boat(s) to which support vessels are attached shall acknowledge the presence of a support vessel on his check-in form and may pay the applicable fee on behalf of the support vessel.
- 24.2 [DP] [NP] All SPVs shall carry a working VHF radio capable of transmitting and receiving normal domestic and international channels, including the VHF Channel.
- 24.3 [DP] SPVs, and team leaders, coaches, and other support personnel, shall stay more than 150 meters to leeward of the starting line, leeward marks, and from any competing boats that are racing.
- 24.4 [DP] [NP] SPVs shall comply with any additional directions given by the OA, the RC or the Jury, including requests for assistance with rescues. Failure to comply may result in the accreditation being withdrawn and all access to the club facilities, grounds and docks being denied.
- 24.5 [DP] [NP] SPVs shall be kept in the places, both afloat and ashore, that they specify during check-in.
- 24.6 Operators of SPVs and all competitors are reminded that J70CR I.3 (Outside Assistance) is in effect. See NoR 1.

## 25. TRASH DISPOSAL

[DP] Trash shall be placed in the appropriate containers when the boats return to shore.

## 26. BERTHING

[DP] Boats shall be kept in their assigned places while in the harbor.

## 27. PRIZES

Prizes will be awarded as specified in the NoR.

## 28. RISK STATEMENT

Competitors participate in the event entirely at their own risk. See RRS 3, Decision to Race. By participating in the event, each competitor agrees to release the race organizers (organizing authority, host yacht club, race committee, protest committee, sponsors, and any others acting in an official capacity for the event) from any and all liability associated with such competitor's participation in the event to the fullest extent permitted by law.

## 29. CONTACT INFORMATION

DIYC Primary Contact	Sandra Soto-Cintron - DIYC General Manager	813-758-7045	<a href="mailto:manager@diyc.org">manager@diyc.org</a>
Event Chair	Kat Robinson-Malone	813-842-0928	<a href="mailto:krobinson75@gmail.com">krobinson75@gmail.com</a>
IJ70 Class Executive Event Technical Committee Chair	Christopher Howell (IM – USA)	440-796-3100	<a href="mailto:howell@ij70classoffice.com">howell@ij70classoffice.com</a>
Principal Race Officer	Chip Till (NRO – USA)	843-556-6554	<a href="mailto:chiptill5351@gmail.com">chiptill5351@gmail.com</a>
Jury Chairman	Rob Stewart (IJ – CAN)	705-341-5351	<a href="mailto:rs.can.ij@gmail.com">rs.can.ij@gmail.com</a>

# Addendum A RACING AREA

Approximate Racing Area (in BLUE circle) & Danger Zones (in RED circles)

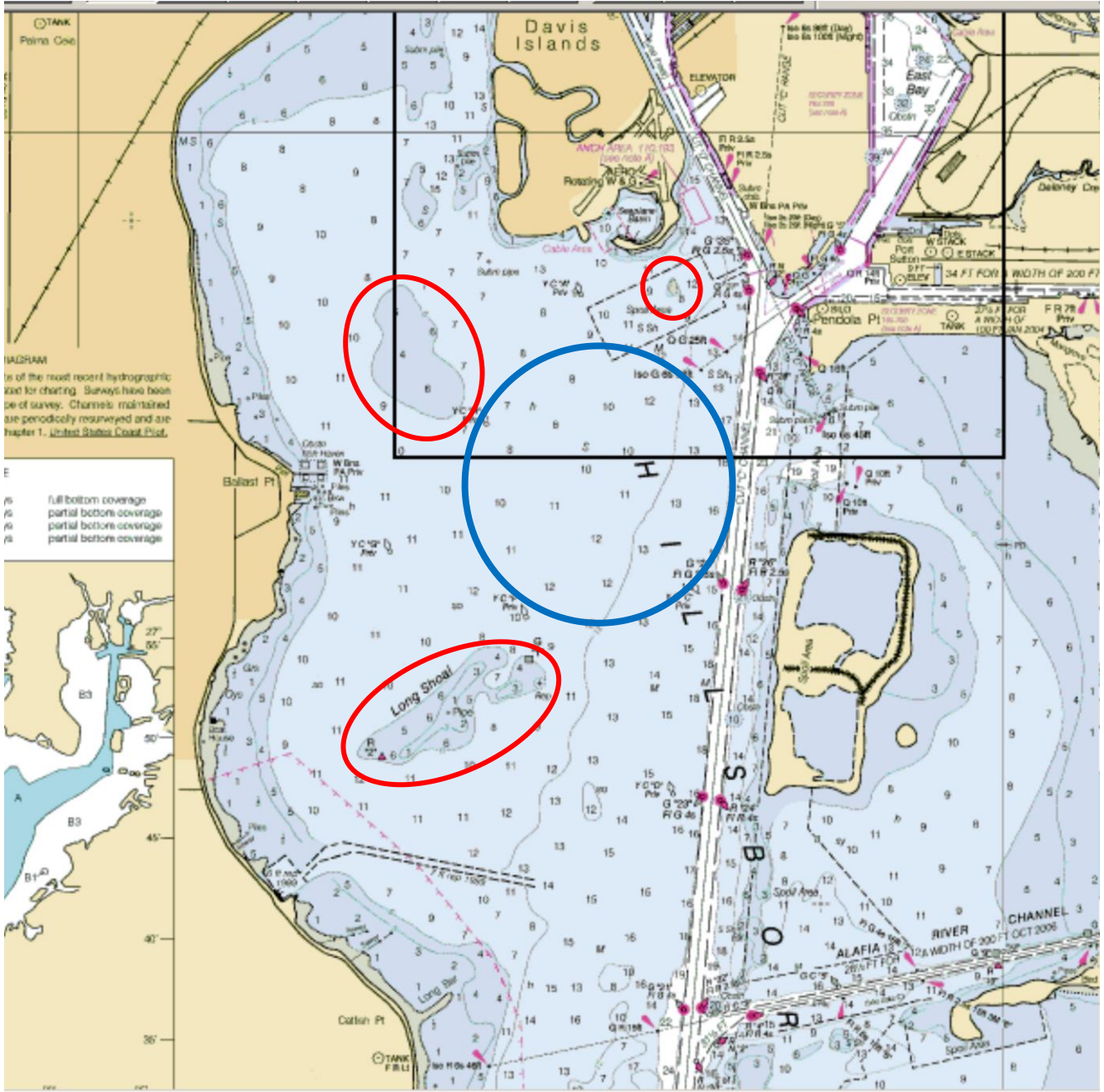

# Addendum B COURSE

## COURSE "W" - WINDWARD/LEEWARD

1 - 1A - 2S/2P - 1 - 1A - FINISH

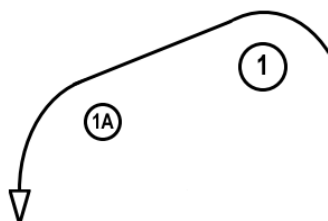

WIND DIRECTION

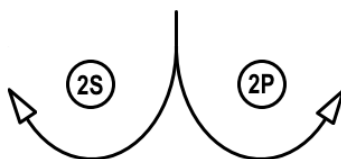

## Addendum C

### RRS APPENDIX P, Special Procedures for Rule 42 is replaced in its entirety with:

#### P1 OBSERVERS AND PROCEDURE

A member of the International Jury, protest committee, or its designated observer (collectively, the “observer”) who sees a boat breaking RRS 42 (Propulsion), RRS 49 (Crew Position; Lifelines), J/70 Class Rule (J70CR) C3.3 (Crew Positioning) or J70CR C9.4(b)(1) (Bowsprit Use) may penalize her by, as soon as reasonably possible, making a sound signal, pointing a yellow or red flag at her and hailing her bow or sail number, even if she is no longer *racing*. A boat so penalized shall not be penalized a second time under rule 42 for the same incident.

#### P2 PENALTIES

When a boat is penalized under rule P1, her penalty shall be a One-Turn Penalty under RRS 44.2. If she fails to take it, she shall be disqualified without a hearing. If an observer signals a penalty after a boat has finished, her penalty shall be a ten percent (10%) scoring penalty calculated per RRS 44.3(c).

#### P3 POSTPONEMENT OR GENERAL RECALL

If a boat has been penalized under rule P1 and the race committee signals a postponement or general recall, the penalty is cancelled.

#### P4 REDRESS LIMITATION

A boat shall not be given redress for an action by an observer under rule P1 unless the action was improper due to a failure to take into account a race committee signal or a class rule.

# Addendum D

## J/70 EQUIPMENT REGULATIONS

### Appendix A: Bow Number Positioning

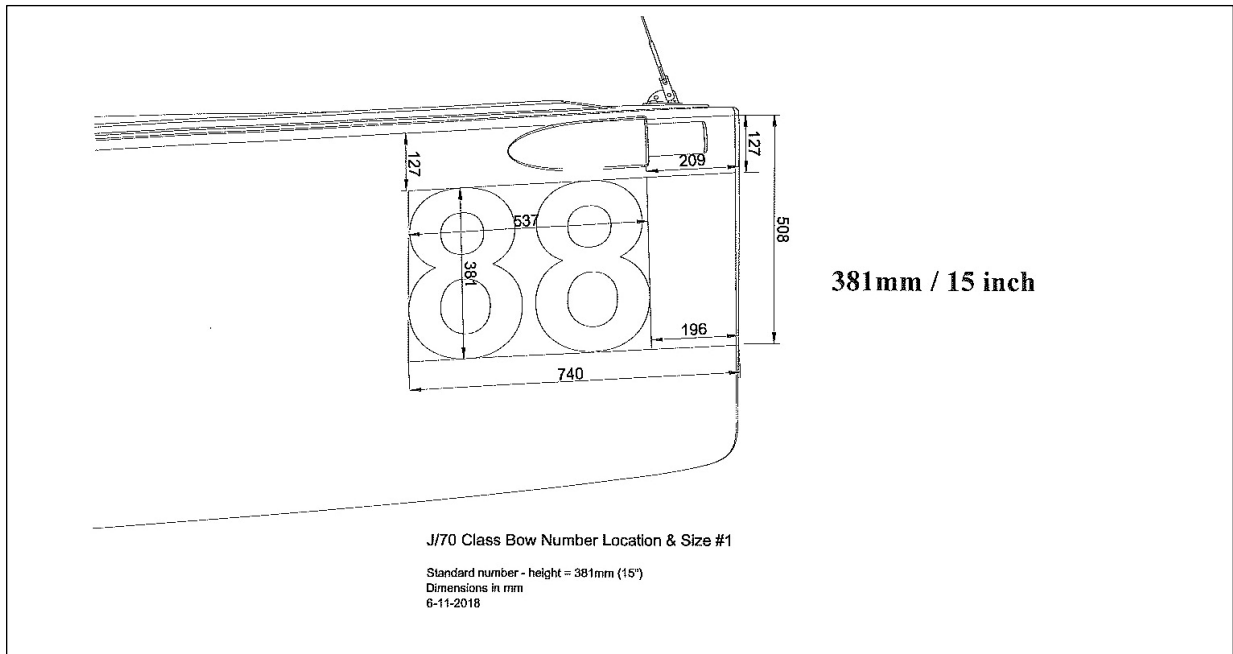

# Addendum E

## Regatta WhatsApp Messaging Group

DIYC J/70 WINTER SERIES  
WhatsApp group

Scan or upload this QR code using the WhatsApp camera to join this group

## **Addendum RS**

### **[NP] Rules and Instructions for Using the Vakaros and RaceSense System**

- RS.1** Each boat shall have a working Vakaros Atlas 2 or Atlas Edge configured for RaceSense at check-in. Boats without a configured Atlas 2 or Atlas Edge may have one provided by the OA, for applicable fees. This shall be mounted as required by the OA or class at all times while racing.
- RS.2** Competitors shall
- a) calibrate their Atlas 2 or Atlas Edge before registration/check-in. It is the responsibility of the competitor to ensure their device remains in proper calibration throughout the event.
  - b) Turn the Atlas 2 or Atlas Edge off after sailing each day. Battery life is approx. 100 hours
- RS.3** The Vakaros RaceSense system will be used by the Race Committee (RC) and the relevant information will be available to all boats.
- RS.4** Instructions for using the electronic Atlas 2 can be found here [Atlas 2 User Guide](#) or Atlas Edge can be found here [Atlas Edge User Guide](#)
- RS.5** Competitors shall take all reasonable measures to keep the Atlas 2 or Atlas Edge safe and operational and promptly notify Vakaros staff on the water or ashore of any device issues.
- RS.6** The countdown to the start on the Atlas 2 or Atlas Edge from RaceSense will be the official time. Signal flags will only be used for information purposes. This changes RRS 26.
- RS.7** The visual identification of boats infringing RRS 29 and 30 by the RC is replaced with electronic identification through the Vakaros RaceSense system, no VHF hail will be made, flag X will not be displayed and no sound will be made modifying RRS 29.1, 30.1, 30.2, 30.3, and 30.4.
- RS.8** Any alleged failure of the Atlas 2 or Atlas Edge, RaceSense system, or communication systems will not constitute grounds to request redress by a boat or the Protest Committee. This changes RRS 61.1(a), 61.1(c).
- RS.9** If the RC vessel displays flag Oscar with a long sound signal before the warning signal of a race, RS.6 and RS.7 inclusive will not apply to that race.
- RS.10** If the RC vessel displays flag Romeo with a long sound signal before the warning signal of a race, Competitors shall restart their Vakaros Atlas or Atlas Edge unit by switching it off, waiting 10 seconds and then switching it back on to reconnect to the RaceSense network. Flag R will remain displayed for a minimum of 2 minutes and will be removed with the next warning signal.
- RS.11** If firmware updates to Atlas 2 or Atlas Edge devices are required between scheduled race days, notice will be sent to all boats via email and/or SMS and or the Regatta What's App Group.